

DS940/DS940T

Passive Infrared Detector

Installation Instructions

1.0 Description

The DS940 is a high performance Passive Infrared (PIR) Motion Sensor which uses advanced signal processing to provide outstanding catch performance and unsurpassed false alarm immunity. It is designed to detect movement in the interior of a structure by sensing the Infrared energy emitted from the human body as it moves across the sensor's field of view. When motion is detected the unit sends an alarm signal to the Control Panel.

2.0 Specifications

- | | |
|--|--|
| <ul style="list-style-type: none"> • Input Power: 9-15 volts DC • Current Draw: 17 mA @ 12 VDC (standby and maximum) • Standby Power: No internal standby battery. <i>For UL Listed Product Installations, 4 hours (68 mAh) standby power must be provided</i> by the control unit or by a Listed burglary power supply. • Relay Form "A" Normally Closed (NC) contact set rated for 125 mA @ 28 volts maximum DC, 18 volts maximum AC for resistive loads. • Tamper: (DS940T only) Normally Closed (with cover on). Contacts rated at 28 VDC, 125 mA max. Connect tamper circuit to a 24hr. protection circuit. | <ul style="list-style-type: none"> • Temperature: -20° to +120°F (-29° to +49°C).
<i>For UL Listed installations, the temperature range is +32°F to +120°F (0°C to +49°C).</i> • Humidity: 0 - 85% non-condensing. • Dimensions: 3 in. x 2.25 in. x 1.5 in. (HxWxD)
(7.6 cm x 5.7 cm x 3.8 cm) • Options: B335 Swivel Mounting Bracket. Use of this bracket may decrease the PIR range and increase dead zones. • Patents: This product is covered by one or more of the following U.S. patents: #4764755, #5670943. |
|--|--|

3.0 Installation

3.1 Remove the cover using a small flat-blade screwdriver.

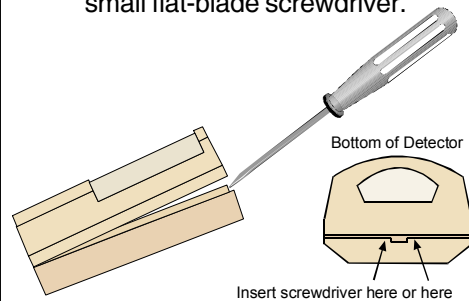

3.2 Press the vertical adjust tab toward the side of the case and lift out the board.

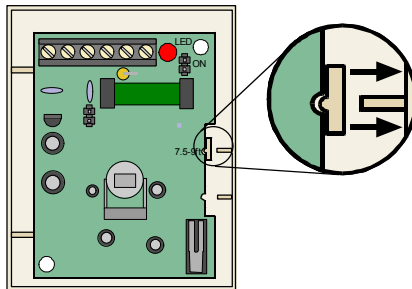

3.3 Select a mounting location. Mount the sensor where an intruder will most likely cross through the coverage pattern.

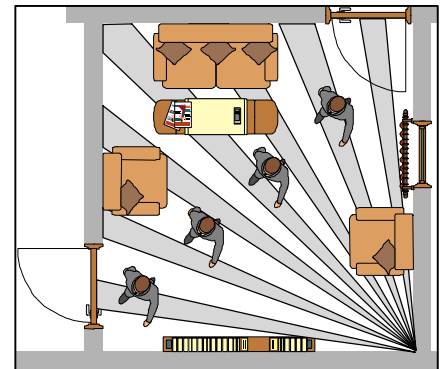

3.4 Avoid.

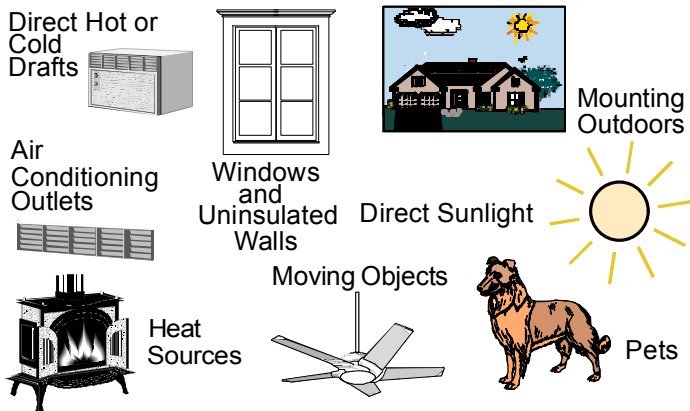

3.5 Position the detector at the correct height.

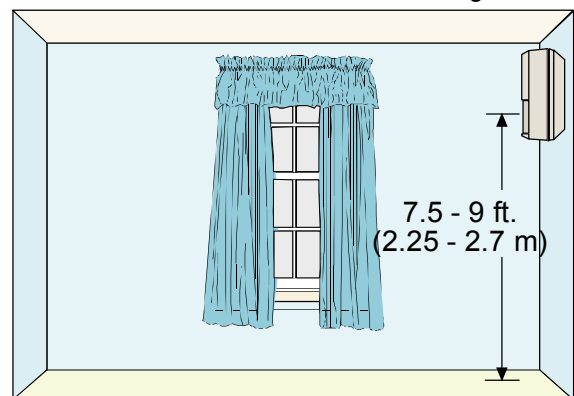

Mount the detector 7.5 - 9 feet (2.25 - 2.7 meters) above the floor

3.6 Mount the unit, using the appropriate mounting holes.

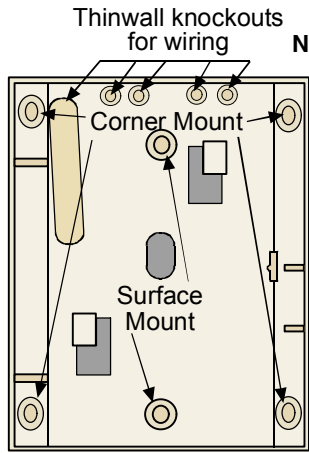

Note: To avoid possible circuit board damage, use **only** the mounting hardware provided in the appropriate punch-out mounting holes. **Remove** [shaded area] Areas if using the B335 Bracket

! Don't overtighten the mounting screws !
Cover may not attach correctly !

3.7 Install the board into the case. Be sure the vertical adjust tab aligns with the correct mounting height.

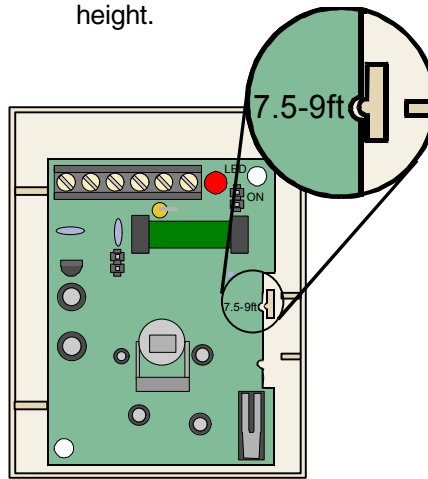

3.8 Wire the Detector.

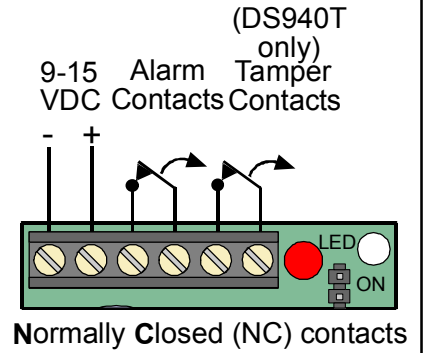

3.9 Select LED Operation

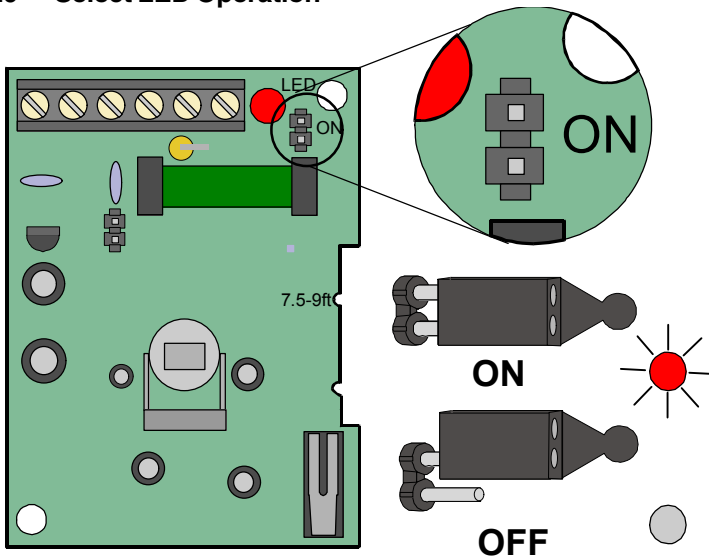

3.10 If look-down is desired, peel away the look-down mask. Do not remove the clear plastic lens.

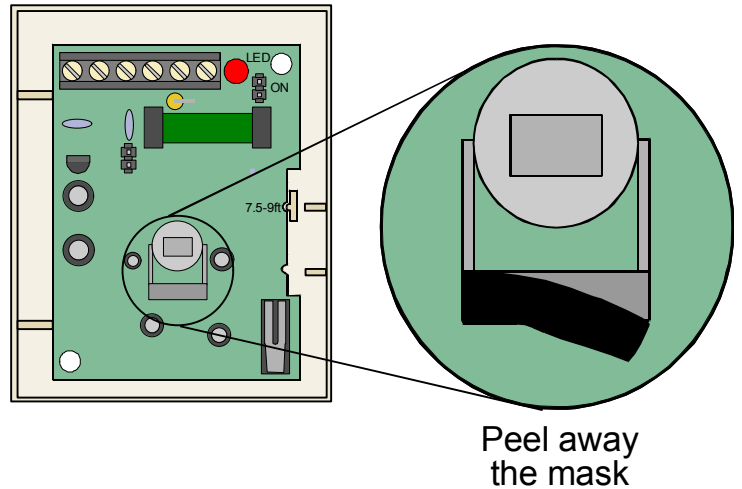

4.0 Walk test the detector. This test should be performed at the time of installation and annually thereafter.

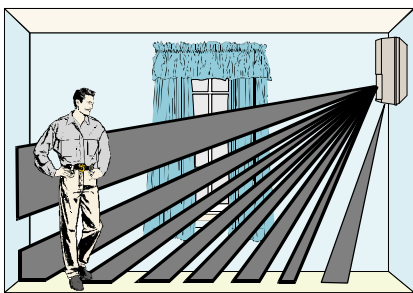

This detector contains an environmental stabilization circuit which requires approximately 2 minutes after initial power-up to warm up. During this time the detector will not respond to any movement.

Please wait 2 minutes after initial power-up to perform any walk tests.

5.0 Coverage Patterns

